

HOW TO REQUEST A QUOTE

This guide will assist you in measuring the room dimensions and providing a drawing in order for eSpecial Needs to configure a quote for your project.

It is recommended that the following information be submitted to eSpecial Needs through our quote request desk at <https://www.especialneeds.com/wall-padding-planning-guide>.

How to complete the wall padding request form

- Complete contact information
- Any project details to describe what needs to be supplied for the room
- Select the type of mount you want for the wall padding
- Select the type of padding and thickness
- Include the desired wall padding height
- Attach and upload a floor plan of the room – See Page 2
- Attach and upload any elevations – See Page 3 and 4
- Attach and upload Images of the room (the more the better)
- Click Submit

The information will be received and one of our product specialists will follow up to clarify any areas on the information provided.

Feel free to contact customer service at 877-664-4565 with any questions.

WALL PADS

When measuring wall pads for proper installation, it is important to draw detailed diagrams, take exact measurements, and take pictures. The photos are important because the manufacturer may see an issue to be addressed or measured.

Simple diagrams provide details that allow precise manufacturing of wall padding to fit the required space. Diagrams needed will be:

- **Floor Plan Drawing** is a top down view of the layout. Imagine slicing the building horizontally 4' above the ground and looking directly down (**Fig 1**)
- **Elevation Drawing** is an interior or exterior view of the vertical elements of the structure. (**Fig 2**)

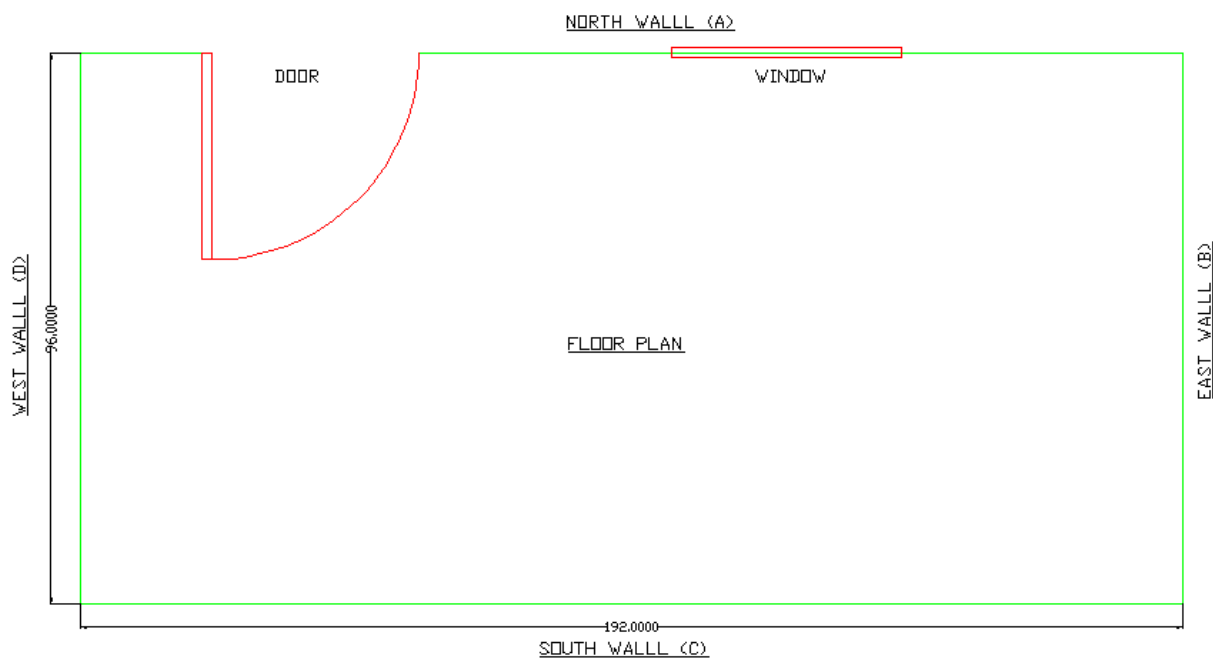

Fig 1

Measuring for Wall Pads (Floor Plan)

When measuring wall pads for a sensory room or de-escalation room please follow these guidelines:

- Begin with a simple floor plan diagram identifying each wall on the diagram: “North, South, East, West” (**Fig 1**). This can be a rough hand drawing in all cases.
- Measure the entire length of each wall and write the measurements on the diagram.
- Mark any large obstacles such as doors, windows, columns, etc. so we can get a clear overview of the area.

WALL PADS

Most sensory rooms or de-escalation areas have some kind of cut-outs that include outlets, light switches, columns, windows, doors, etc. We customize pads to fit all of these areas. Wall padding can be installed on drywall, steel, wood or concrete surfaces. Covering corners, columns, and doors provides a continuous and professional looking installation.

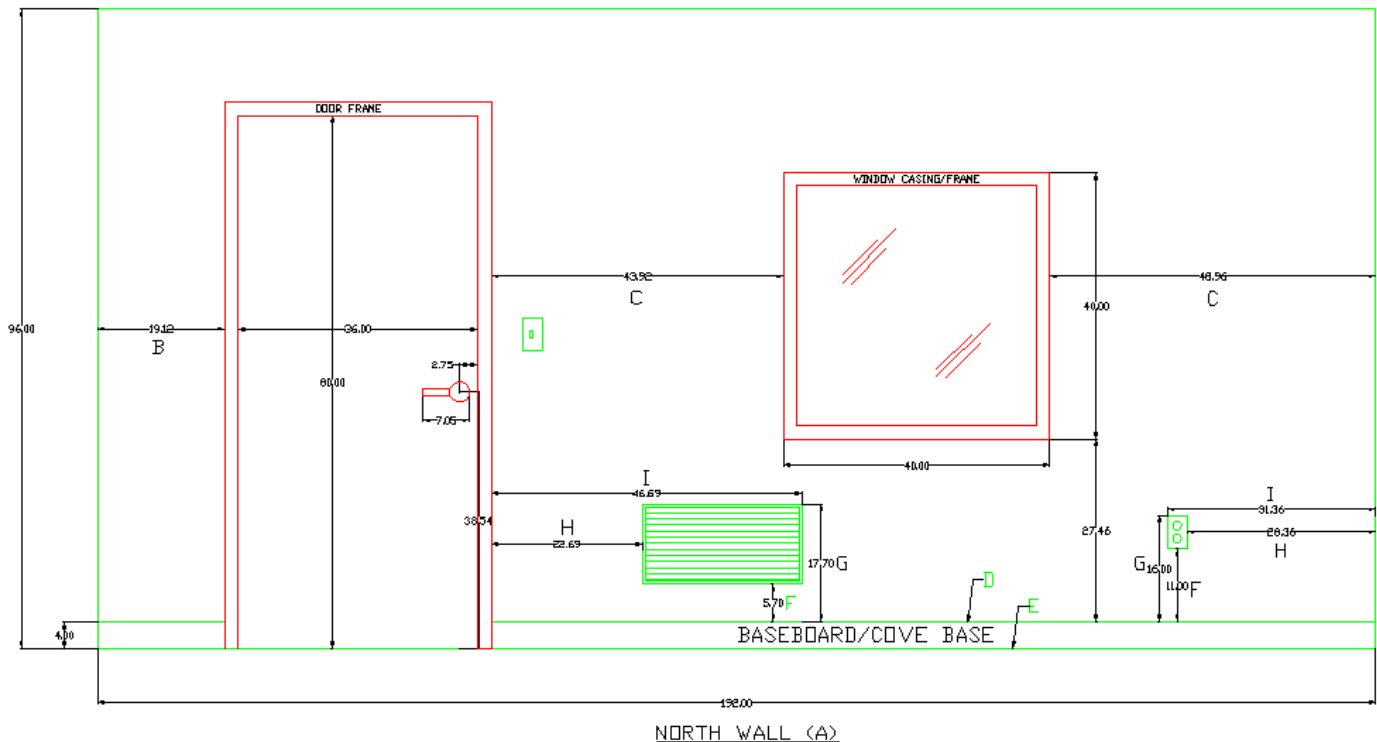

Measuring for Wall Pads (Wall Elevation)

Draw a simple wall elevation diagram of each wall to receive wall padding.

1. Indicate the wall you are measuring and its full length on the drawing, i.e. “North Wall – 192” **(Fig 2)**.
2. Determine the finish height of your wall padding:
 - a. If cove base is commercial style and is flat against the wall, you can start the padding from the floor and apply padding over cove base
 - i. Measure from the floor up and strike a horizontal chalk line along the wall. Wall padding typically starts 4 to 6 inches from the floor **(fig. E)**
 - b. If baseboard protrudes from the surface of the wall – install above baseboard:
 - i. Measure from the baseboard up and strike a horizontal chalk line along the wall. Wall padding typically starts 4 to 6 inches from the floor. **(fig. D)**
3. Starting from a corner, measure outward from the corner across the wall until you reach a landmark or the opposite corner of the wall **(fig B)** stopping where you want the padding to end. A landmark can be a door, case opening, window, column, or even the farthest wall.

4. Landmark notes:
 - a. Wall padding cannot cover frames or casing that protrude from the surface of the wall. If the door or window has a frame/casing that protrudes from the surface of the wall, stop your measurement at edge of frame.
5. If padding is interrupted and continues beyond a landmark (like a door, window or column) measure from the opposite side of the landmark to where the padding will end (**fig. C**).
6. Use the top of the baseboard as your wall pad mounting point for the bottom of the pads. This is where most pads will start (**fig. D**). Begin all measurements from this point, Or, if there is no baseboard/flat cove base, measure from the floor, giving the height from the floor to where the pads will be mounted (**fig. E**).

How to Measure for Cut-Outs in Wall Pads

To measure for cut-outs in wall padding, first measure for the pads, then provide measurements from the baseboard or floor to every object that would require a cut-out (or hole in the pads): vents, light switches, outlets, thermostat, windows, etc.

1. Measure the following for each cut-out:
 - from the mounting point to the bottom of the object (**fig. F**)
 - from the mounting point to the top of the object (**fig. G**)
 - from the closest landmark to the closest side of the object (**fig. H**)
 - from the closest landmark to the farthest side of the object (**fig. I**)

Photos and Images

1. Finally, provide a digital photo of the entire wall, along with your measurements.

DOORS

In some cases, you will want to install padding over a door. We customize pads to fit all shapes, sizes, and designs. Continuing the padding over the doors provides additional protection, as well as, a continuous and professional looking installation.

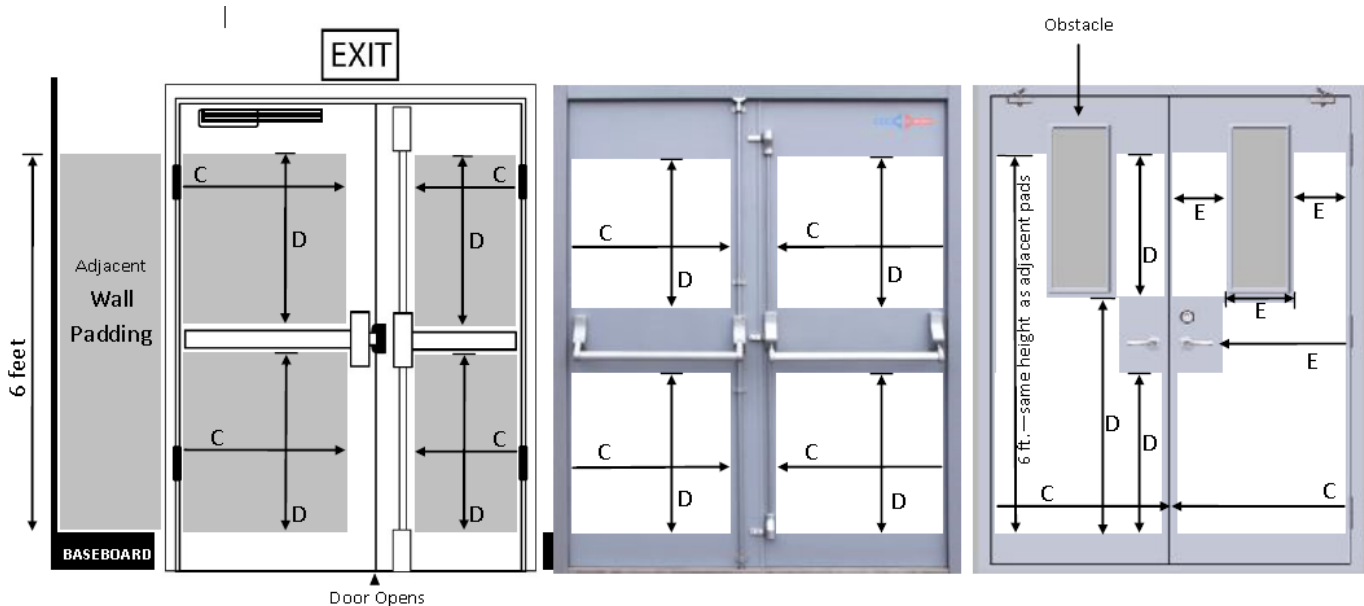

Measuring Doors

1. Indicate the location of the door you are measuring on your floor diagram, i.e. “Door - West Wall” (**Fig A**).
2. Indicate if the door swings outward or inward to the room on the Floor Plan diagram
3. It is sometimes easier to visualize your final installation if you tape construction paper over the areas that you want covered. Allow for 1” margins all around.
4. When measuring, be sure to take into account the space needed to push all handles down. Tape the construction paper, and then test the door handles.
5. Doors should be close when measuring.
6. Padding can begin at the bottom of the door or at the top of the baseboard to match up with your wall padding. Padding ends where the adjacent wall pads stop. If wall padding is taller than door, a filler pad may be supplied to install above the door.
7. Measure the exact width of each padded area—begin a 1” away from the door hinge and end 1” inch from any landmark such as a door hinge, door stop on frame, locking mechanism, or where the door opens (**Fig C**).
8. For doors with obstacles, measure the exact heights (**Fig D**) and widths (**Fig E**) within each individual padded section that has obstacles. Measure from landmarks to any door mechanisms, bars, handles, and windows, as needed.
9. Provide a digital image of the door, along with your measurements.

MEASURING COLUMNS, CORNERS AND I-BEAMS

We design pads to cover columns, corners, and I-Beams. The pads provide additional protection, as well as, a continuous professional look. We design pads to cover unique columns of all shapes:

- 3-sided, 4-sided, Rectangular, Tapered, Free standing or protruding from the wall

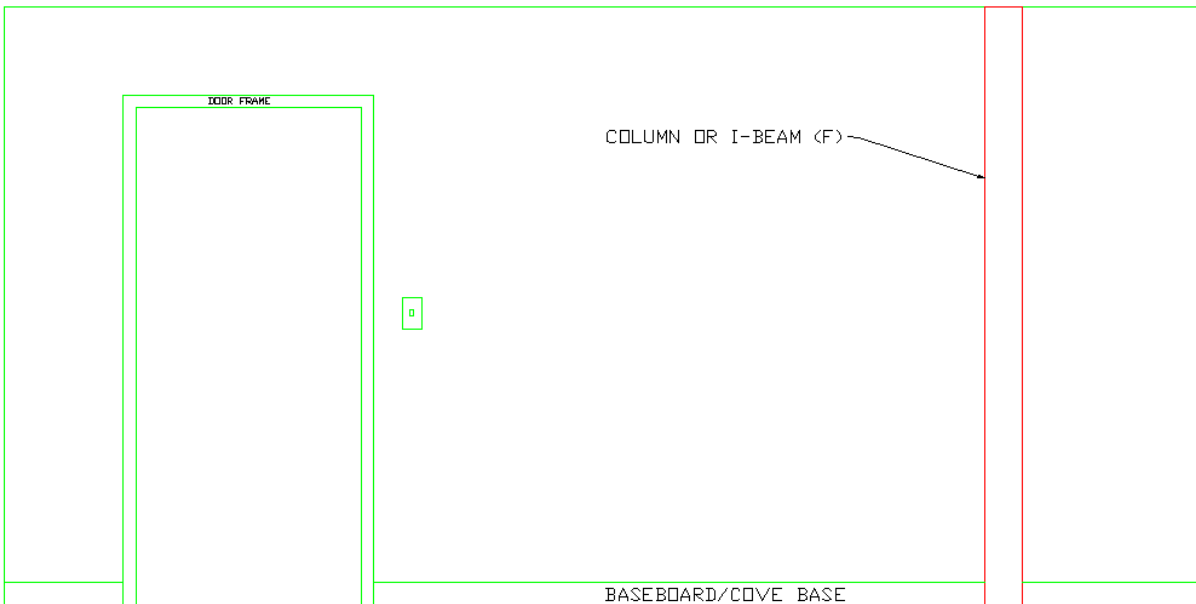

Draw a simple diagram of each column or I-beam

- Indicate the location of the column, corner, or I-Beam on your wall diagram.
- Measure from the closest landmark to where the beam begins on the wall (**Fig F**).
 - A landmark can be a corner, door, or window.
- Specify what each column or beam is made of: Drywall, Concrete/Block, Steel, Wood

Measuring Columns

- Measure the height of the padded area of the column - either from floor level or from the top of the baseboard/cove base - to the top of the pads (**Fig A**).
- Measure the width of the beam (**Fig C**). It is rare, but if the beam/column gets wider, measure at both the highest and lowest points.
- Measure the depth of the beam at the lowest point - from the wall to the front on both sides (**Fig B**)
- Measure the depth of the beam at the highest point (where the pad ends) - from the wall to the front of the beam on both sides (**Fig D & E**).
- Provide a photo of the entire wall, as well as, a close up of the column or I-beam.

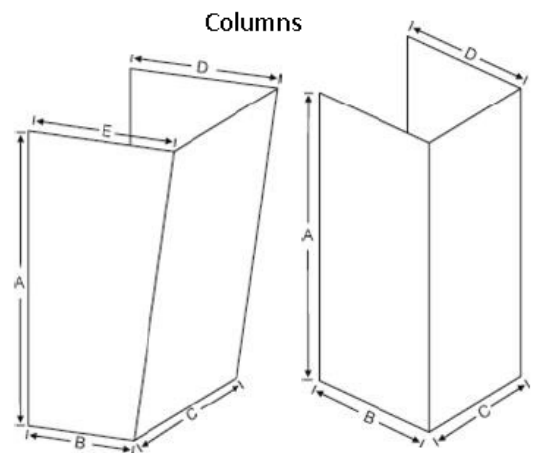

CORNER PADS

At the end of a wall, there may be corners with exposed edges that could be covered for added protection. We can manufacture this padding to your specifications for a continuous look.

Measuring Corner Pads

- Measure the height of the entire padded area - either from floor level or from the top of the baseboard/mopboard - to the top of the pads (**Fig A**).
- Measure the depth of the corner - from the wall (A) to the point where the two sides converge at the angle (**Fig B**).

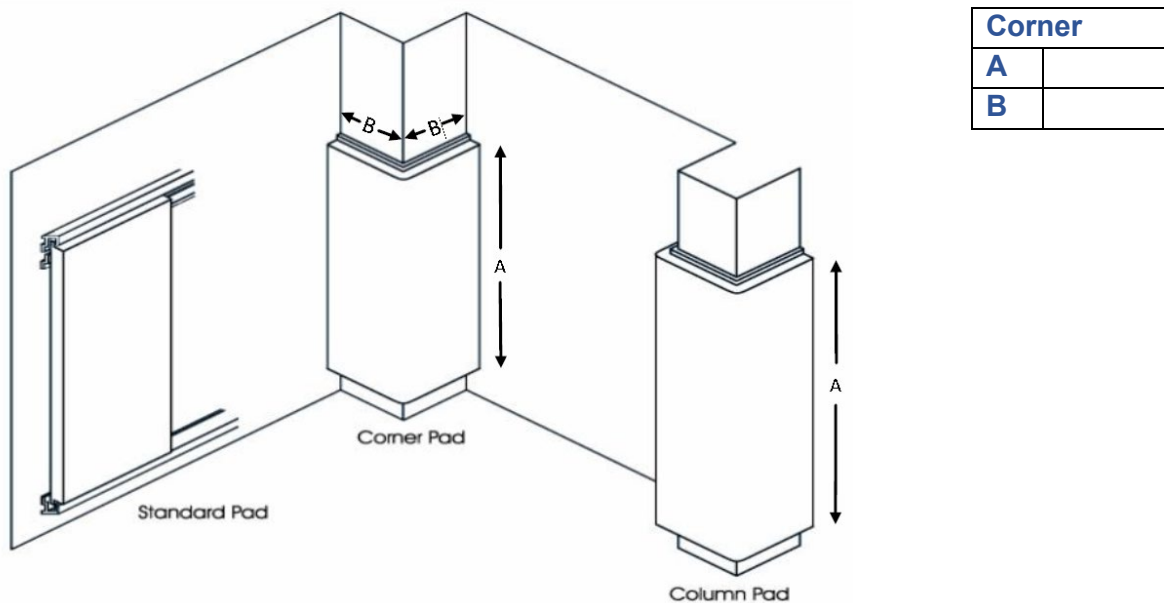

I-BEAM PADS

I-Beams can be free standing or protruding from the wall. The pads are designed to fit snugly around the face of the beam and are held securely in place with self-adhesive hook and loop fasteners (Velcro). The standard I-Beam pad fits over an 8" face (**A**) and is 6' tall (**B**).

Measuring I-Beams

- Measure width of the face (**A**).
- Measure the height from where the pad begins to where it ends (**B**).
- Measure the depth of the entire beam, beginning at the face (**C**).
- Measure the width of the T-bar (**D**).
- Measure from the closest landmark to where the beam begins (**F**).

I-Beam	
A	
B	
C	
D	
E	
F	

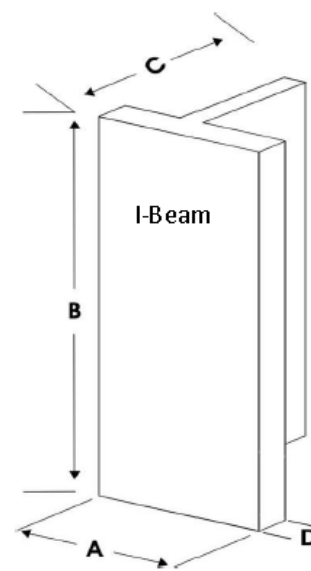

POST PADDING

Post pads come in a variety of sizes and shapes, but you don't have to be a math expert to measure for their installation. Round can be measured in a few simple steps.

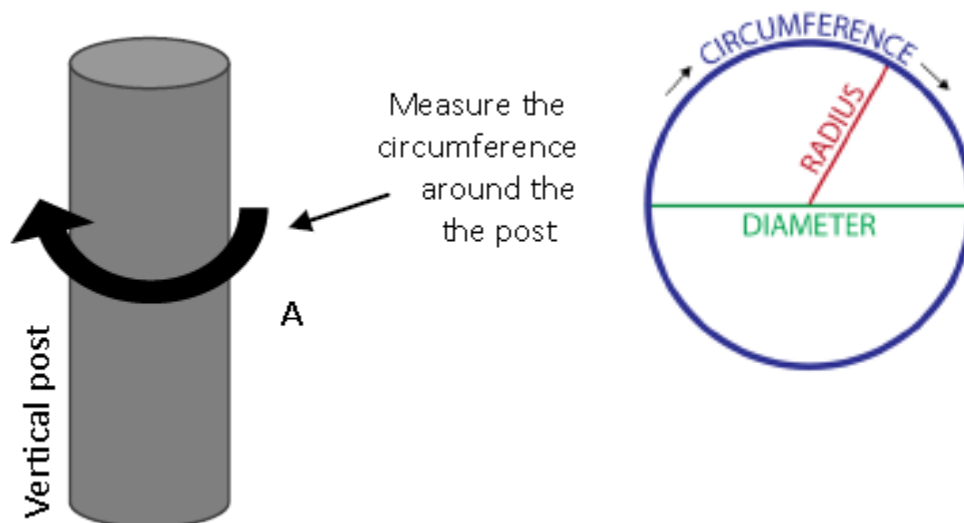

Measuring for Round Post Padding

1. First measure the circumference of the post (**Fig A**), which is the measurement around the post. Using either a soft tape measure, or a piece of string, wrap it tightly and evenly around the post, mark the string, and then simply measure the string. This will give you the circumference. The reason for the string is because hard plastic tape measures are inflexible, often resulting in an inaccurate reading.

_____ Circumference (Distance around the post)

2. Measure for the height of the post pad. The standard height of a post pad is 6', but post padding can be any height, width, or shape to accommodate different activities. Before providing the height, consider the height of the users in the room.

_____ Height of post pad

Thickness: The industry standard for foam thickness of a post pad is 4". Padding is also available in 5" and 6" depths. On occasions when the post sits in restricted space and cannot accommodate thicker foam, 2" high density foam is recommended. 2" foam needs to be dense enough to absorb an impact before a player hits the post.

Measuring for Square Post Padding

1. Draw the post and notate the following:

Measurements for all four (4) sides of the post.

- Side A _____
- Side B _____
- Side C _____
- Side D _____

In every case, it is prudent to submit an accompanying photo with the measurements. This allows us to visually review the project and be alerted to any concerns in advance.

2. Measure for the height of the post pad. The standard height of a post pad is 6', but post padding can be any height, width, or shape to accommodate different activities. Before providing the height, consider the height of the users in the room.

_____ Height of post pad

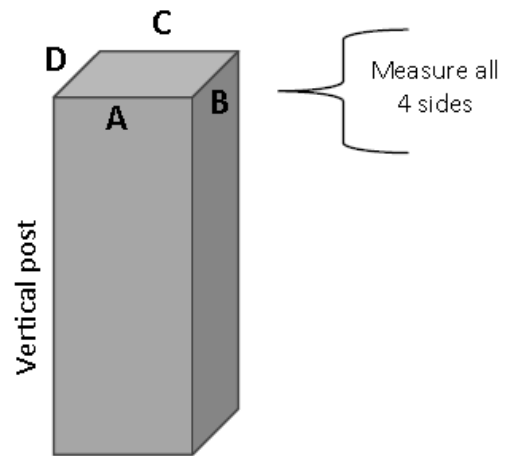

Thickness: The industry standard for foam thickness of a post pad is 4". Padding is also available in 5" and 6" depths. On occasions when the post sits in restricted space and cannot accommodate thicker foam, 2" high density foam is recommended. 2" foam needs to be dense enough to absorb an impact before a player hits the post.